



Software

Matrox Imaging Library (MIL) >>>

Release 9.0



Application development toolkit for image analysis, machine vision, medical imaging, and video analytics



Overview

Industrial imaging tools

Matrox Imaging Library (MIL) is a comprehensive collection of software tools for developing industrial imaging applications. MIL includes tools for every step in the process: from application feasibility, to prototyping, through to development and ultimately deployment.

The toolkit features interactive software and programming functions for image capture, processing, analysis, annotation, display and archiving. These tools are designed to enhance productivity, thereby reducing the time and effort required to bring your solution to market.

Image capture, processing and analysis operations have the accuracy and robustness needed to tackle the most demanding applications. These operations are also carefully optimized for speed to address the severe time constraints encountered in many applications.

Benefits

- **Solve applications rather than develop underlying tools** by leveraging a toolkit with a 15-year history of reliable performance
- **Tackle applications with utmost confidence** using field-proven tools for analyzing, locating, measuring, reading, and verifying
- **Harness the full power of today's hardware** through optimizations exploiting SIMD, multi-core CPU¹, multi-CPU¹, GPU² and FPGA technologies
- **Easily support platforms ranging from smart cameras to HPC clusters** via a single consistent and intuitive API
- **Obtain live images from the interface of choice** through support for analog, Camera Link[®], GigE Vision^{™2}, IEEE 1394 IIDC², and RS-422/LVDS transmission formats
- **Maintain flexibility and choice** by way of 32-bit and 64-bit Windows[®], and Linux support
- **Make the best use of available programming know-how** with support for C, C++, C# and Visual Basic[®] languages
- **Further increase productivity and reduce development costs** by receiving training and assistance from our team of imaging experts

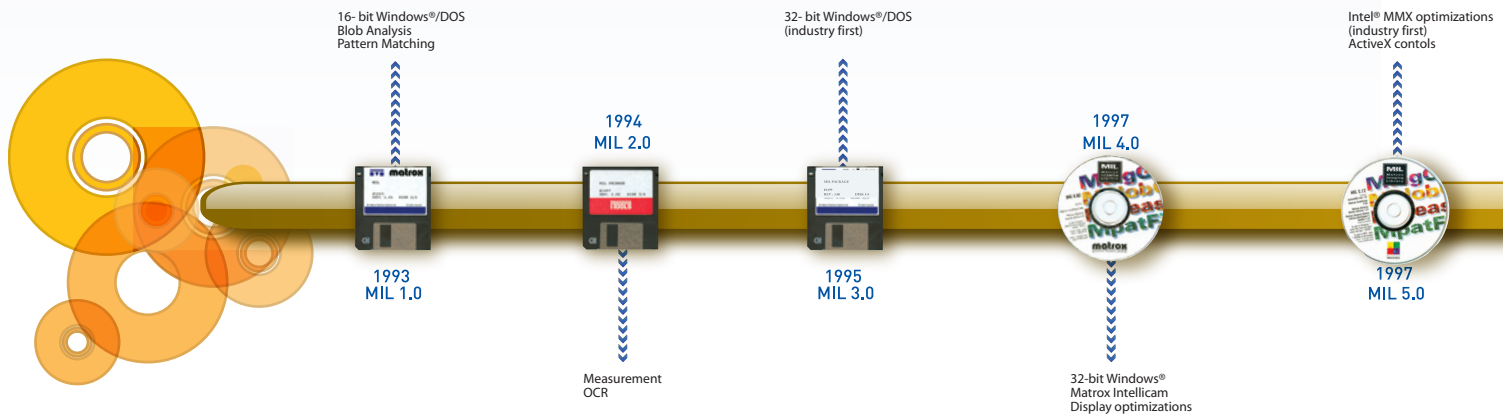

MIL has evolved to meet industry requirements (for performance and value).

Overview (cont.)

About MIL development

First released in 1993, MIL has evolved to keep pace with and foresee new industry requirements. It was conceived with an easy-to-use coherent application programming interface (API) that has stood the test of time. MIL pioneered the concept of hardware independence with the same API for different image acquisition and processing platforms. A team of highly skilled and dedicated computer scientists, mathematicians, software engineers and physicists continue to maintain and enhance MIL.

MIL is developed using recognized industry best practices including peer review, user involvement, and daily builds. Users are asked to evaluate and report on new tools and enhancements, which strengthens and validates releases. Ongoing MIL development is integrated and tested as a whole on a daily basis.

About MIL SQA

In addition to the thorough manual testing performed prior to each release, MIL continuously undergoes automated testing during the course of its development. The automated validation suite, consisting of both systematic and random tests, verifies the accuracy, precision, robustness, and speed of image processing and analysis operations. Results, where applicable, are compared against those of previous releases to ensure that performance remains consistent. The automated validation suite runs continuously on hundreds of systems simultaneously, rapidly providing wide-ranging test coverage. The systematic tests are performed on a large database of images representing a broad sample of real-world applications.

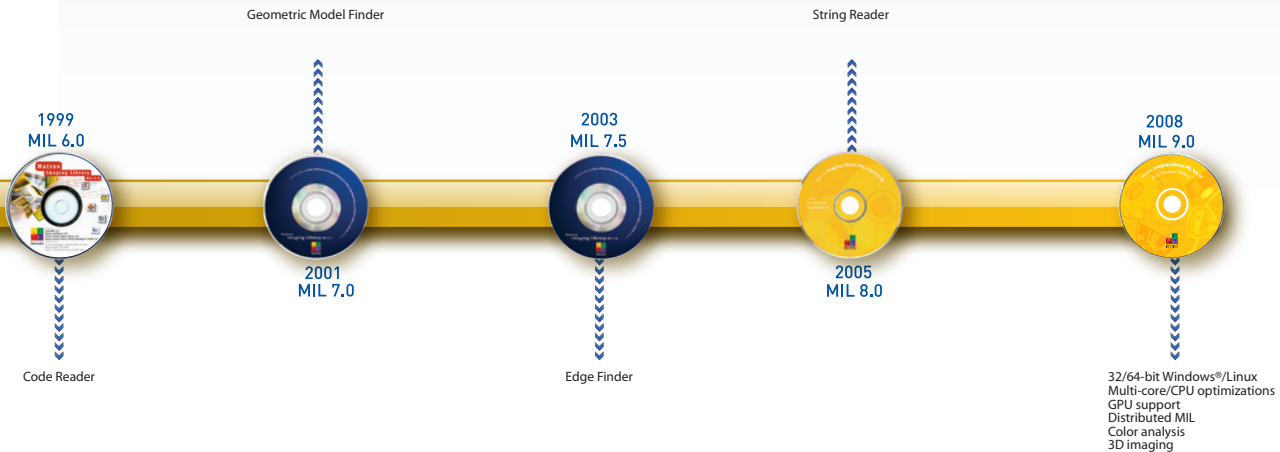

Overview (cont.)

Main new features in release 9

- Support for new operating systems
 - 32-bit Windows® Vista®
 - 64-bit Windows® XP and 64-bit Windows® Vista®
 - 32-bit and 64-bit Linux
 - Windows® CE 6.0³
- Image processing using a Graphics Processor Unit (GPU)²
- Distributed MIL technology
- 3D calibration and reconstruction tools¹
- Color analysis tools¹
- Enhanced 1D/2D code verification tool¹
- Unified String Reader tool context for ANPR applications¹
- Speed optimizations for multi-core CPU / multi-CPU architectures¹

Industries served

MIL tools are used to put together solutions for the agricultural, aerospace, automotive, beverage, consumer, construction material, cosmetic, electronic, food, flat panel display, freight, machining, medical device, medical diagnostic, paper, packaging, pharmaceutical, printing, resource, security, semiconductor, shipping, textile, and transportation industries.



About Matrox Imaging

Founded in 1976, Matrox is a privately held company based in Montreal, Canada. Graphics, Video and Imaging divisions provide leading component-level solutions for commercial graphics, professional video editing and industrial imaging respectively. Each division leverages the others' expertise and industry relations to provide more innovative timely products.

Matrox Imaging is an established and trusted supplier to top OEMs and integrators involved in the manufacturing, medical diagnostic and security industries. The components delivered consist of cameras, interface boards and processing platforms, all designed to provide optimum price-performance within a common software environment.



Image analysis / measurement tools

Field-proven tools

Central to MIL are tools for calibrating, enhancing and transforming images, locating objects, extracting and measuring features, reading character strings, and decoding and verifying identification marks. These tools are carefully developed to provide outstanding performance and reliability, and can be used within a single computer system or distributed across several computer systems.

Pattern recognition

MIL includes two tools for performing pattern recognition: Pattern Matching and Geometric Model Finder. These tools are primarily used to locate complex objects for guiding a gantry, stage or robot, or for directing subsequent measurement operations.

The MIL Pattern Matching tool is based on normalized grayscale correlation (NGC), a classical technique that finds a pattern by looking for a similar spatial distribution of intensity. A hierarchical search strategy lets this tool very quickly and reliably locate a pattern, including multiple occurrences, which are translated and slightly rotated, with sub-pixel accuracy. The tool performs well when scene lighting changes uniformly, which is useful for dealing with attenuating illumination. A pattern can be trained manually or determined automatically for alignment. Search parameters can be manually adjusted and patterns can be manually edited to tailor performance.

The MIL Geometric Model Finder (GMF) tool is based on a patented⁴ technique that uses geometric features (e.g., contours) to find an object. The tool quickly and reliably finds multiple models, including multiple occurrences that are translated, rotated, and scaled with sub-pixel accuracy. GMF locates an object that is partially missing and continues to perform when a scene is subject to uneven changes in illumination; relaxing lighting requirements. A model can be trained manually from an image, obtained from a CAD file or determined automatically for alignment. A model can also be obtained from the MIL Edge Finder tool, where the geometric features are defined by color boundaries and crests or ridges in addition to contours. Physical setup requirements are eased when GMF is used in conjunction with the MIL Calibration tool as models become independent of camera position. GMF parameters can be manually adjusted and models can be manually edited to tailor performance.

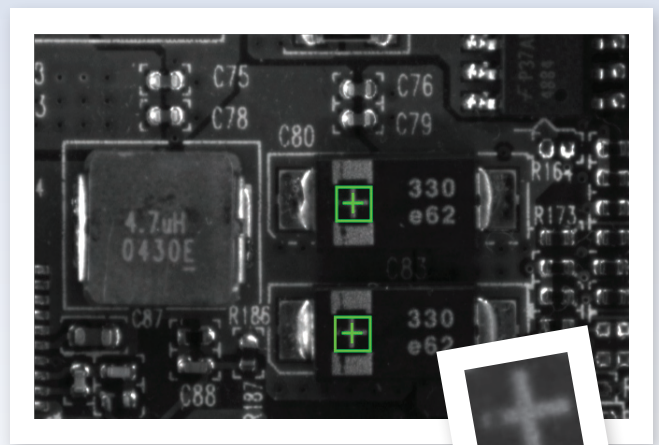

MIL Pattern Matching

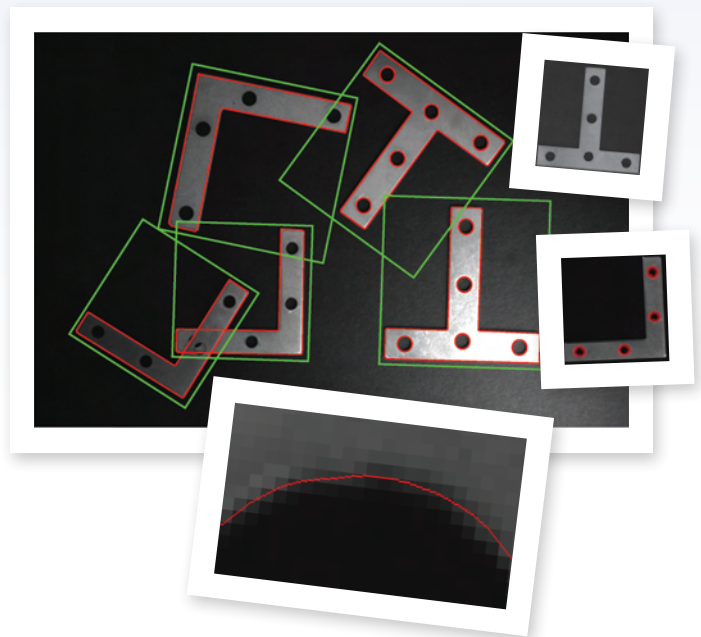

MIL Geometric Model Finder

Image analysis / measurement tools (cont.)

Feature extraction and analysis

MIL provides a choice of tools for image analysis: Blob Analysis and Edge Finder. These tools are used to identify and measure basic features for determining object presence and location, and for further examining objects.

The MIL Blob Analysis tool works on segmented binary images, where objects are previously separated from the background and one another. The tool, using run-length encoding, very quickly identifies blobs and can measure over 50 binary and grayscale characteristics. Measurements can be used to sort and select blobs. The tool also reconstructs and merges blobs, which is useful when working with blobs that straddle successive images.

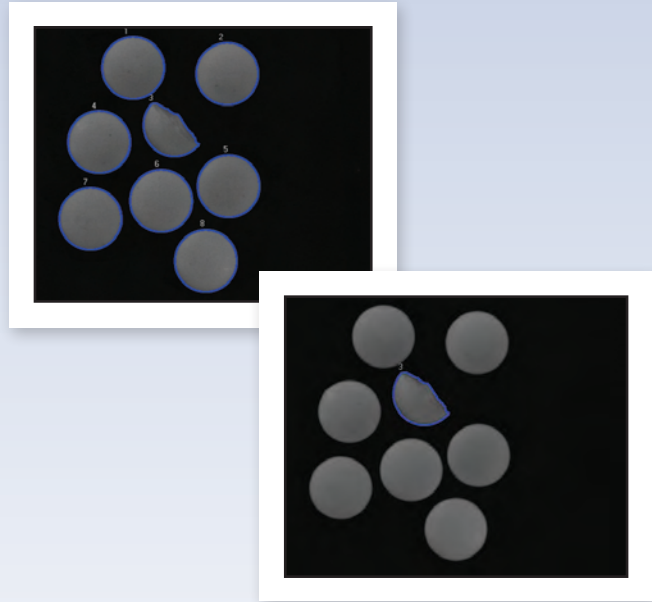

MIL Blob Analysis

The MIL Edge Finder tool is well suited for scenes with changing uneven illumination. The tool, using a gradient-based (as well as a Hessian-based) approach, quickly identifies contours (as well as crests or ridges) in monochrome or color images and can measure over 50 characteristics with sub-pixel accuracy. Measurements can be used to sort and select edges. The edge extraction method can be adjusted to tailor performance.

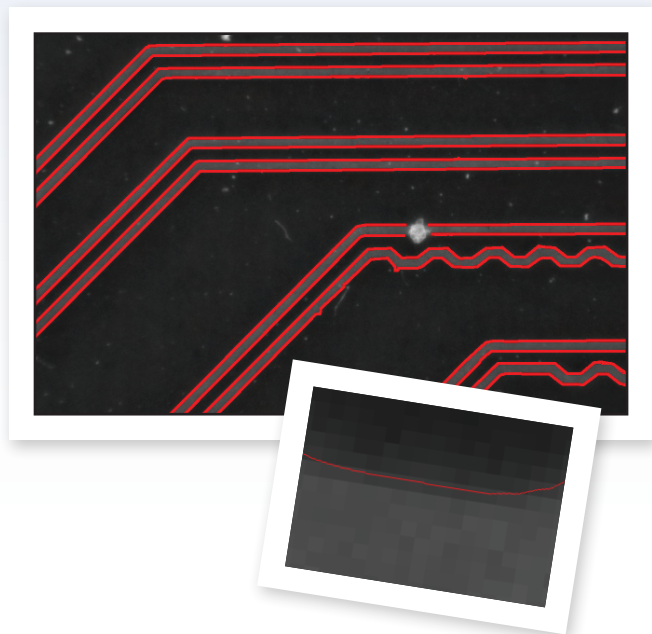

MIL Edge Finder

Image analysis / measurement tools (cont.)

1D and 2D measurements

MIL offers a pair of tools for measuring: Measurement and Metrology. These tools are predominantly used to assess manufacturing quality.

The MIL Measurement tool uses the projection of image intensity to very quickly locate and measure straight edges or stripes within a carefully defined rectangular region. The tool can make several 1D measurements on edges and stripes, as well as between edges or stripes.

The MIL Metrology tool is intended for 2D geometric dimensioning and tolerancing applications. The tool quickly extracts edges within defined regions to best fit geometric features. It also supports the construction of geometric features derived from measured ones or defined mathematically. Geometric features include arcs, circles, points, and segments. The tool validates tolerances based on the dimensions, positions, and shapes of geometric features. The tool's effectiveness is maintained when subject to uneven changes in scene illumination, which relaxes lighting requirements. The expected measured and constructed geometric features, along with the tolerances, are kept together in a template, which is easily repositioned using the results of other locating tools. This along with the use of the MIL Calibration tool enables templates to be independent of camera position.

Color analysis'

MIL includes tools for color distance, projection, matching and conversion. The distance and projection tools are commonly used to set up subsequent analysis. The distance tool reveals the extent of color differences in and between images, while the projection tool separates features from an image based on their colors. The projection tool also enhances color to grayscale conversion for analysis using other grayscale tools. The color matching tool is used to identify objects based on their color. These tools work with the RGB, HSL, and CIE LAB color spaces.

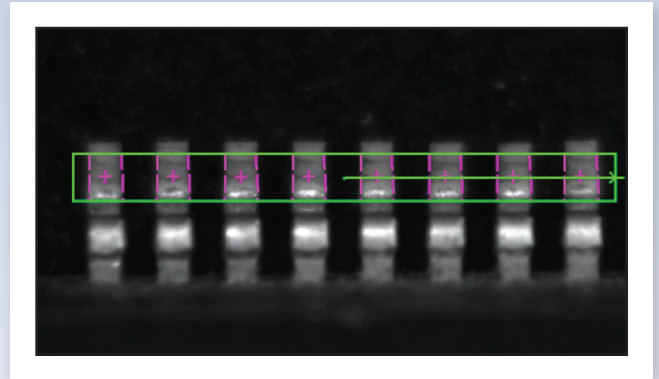

MIL Measurement

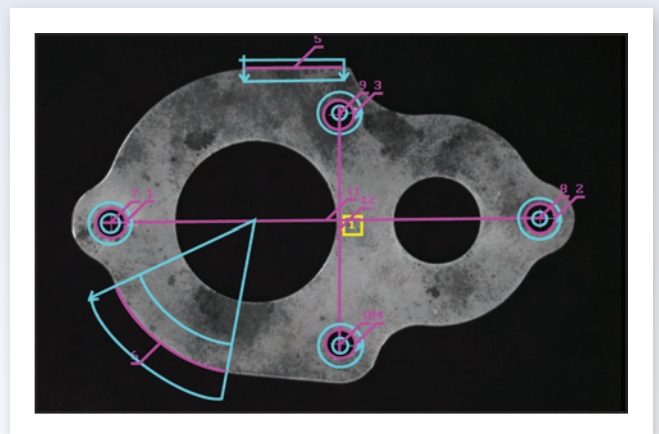

MIL Metrology

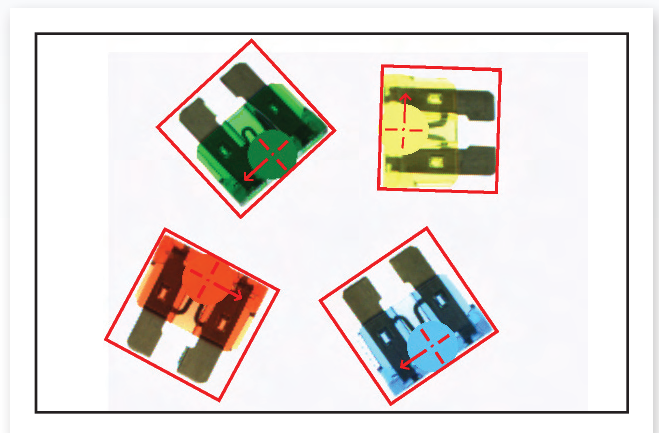

MIL Color Analysis

Image analysis / measurement tools (cont.)

Character recognition

MIL provides two tools for character recognition: OCR and String Reader. These tools read character strings that are engraved, etched, marked, printed, punched or stamped on surfaces.

The MIL OCR tool utilizes a template matching method to very quickly read a string with a known number of evenly spaced characters. Once calibrated, the tool reliably reads strings with consistent character size even if the strings themselves are at an angle. Characters can come from one of the provided MICR E-13B, SEMI M12-92 and SEMI M13-88 fonts or a user-defined font. Character strings can be subject to user-defined grammar rules to further increase recognition rates.

The MIL String Reader tool is based on a sophisticated technique that uses geometric features to quickly locate and read character strings in images where characters are well separated from the background and from one another. The tool handles strings with a known or unknown number of evenly or proportionally spaced characters. It accommodates changes in character angle with respect to the string, aspect ratio, scale, and skew, as well as contrast reversal. Strings can be located across multiple lines and at a slight angle. The tool reads from multiple pre-defined (TrueType™ and Postscript™) or user-defined Latin-based fonts. Also included is a ready-made unified context for automatic number plate recognition (ANPR) that works with any Latin-based license plate¹. In addition, character strings can be subject to user-defined grammar rules to further increase recognition rates. The tool is designed for ease-of-use and includes String Expert, a utility to help fine-tune settings and troubleshoot poor results.

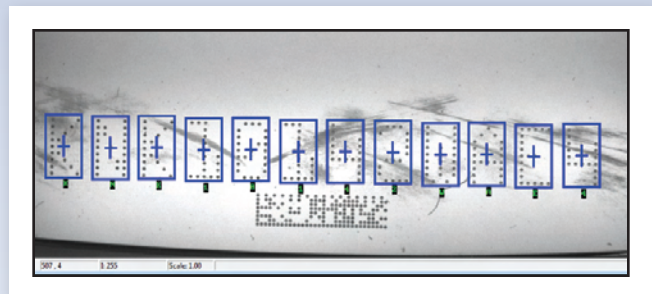

MIL OCR

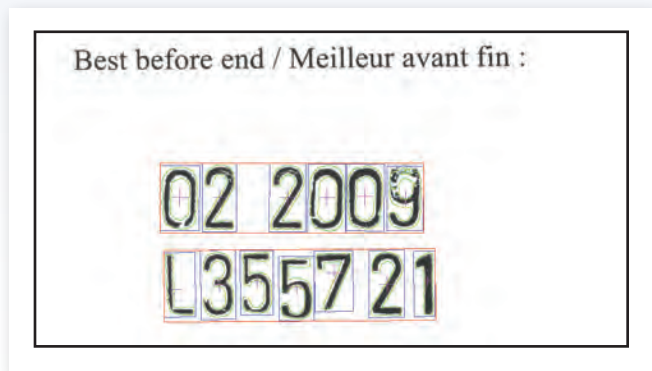

MIL String Reader

Image analysis / measurement tools (cont.)

1D and 2D code reading and verification

MIL offers Code Reader a fast and dependable tool for locating and reading 1D, 2D and composite identification marks. The tool handles rotated, scaled, and degraded codes in tough lighting conditions. It simultaneously reads multiple 1D codes and reads small codes found in complex scenes. The tool can return the orientation, position, and size of a code. In addition to reading, the tool also verifies the quality of a code based on the ANSI/AIM and ISO/IEC¹ grading standards.

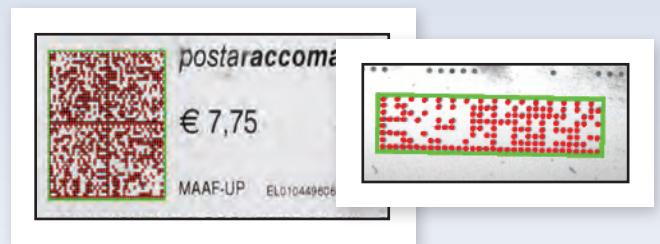

MIL Code Reader

Registration

MIL has an image registration tool to transform images taken from different vantage points into a unified scene, which would be impractical or impossible to achieve using a single camera. It can also align an image to a reference for subsequent inspection. The tool contends with not only translation, but also with perspective including scale. Alignment to a reference image or of neighboring images is performed with sub-pixel accuracy and is robust to local changes in contrast and intensity. In addition, the tool can be used for super-resolution where a sharper image is created from a series of images taken from roughly the same vantage point, which is useful for dealing with mechanical vibration¹.

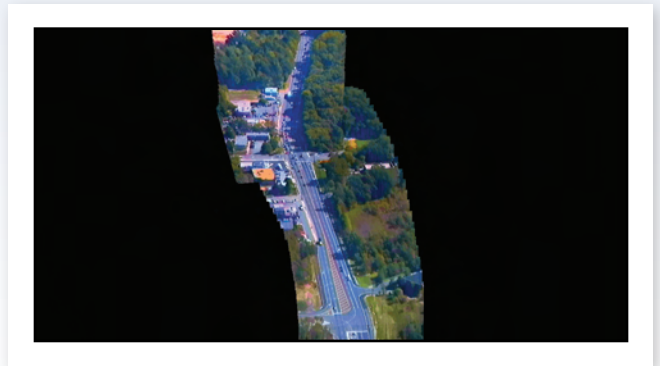

MIL Registration

2D calibration

Calibration is a routine requirement for imaging. MIL includes a 2D calibration tool to convert results (i.e., positions and measurements) from pixel to real-world units and vice-versa. The tool can compensate results and even an image itself for camera lens and perspective distortions. Calibration is achieved using an image of a grid or just a list of known points.

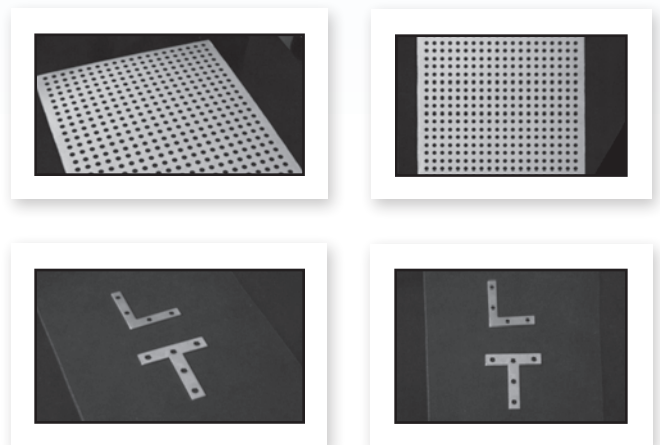

MIL 2D Calibration

Image analysis / measurement tools (cont.)

3D calibration and reconstruction¹

MIL provides 3D calibration and reconstruction tools for pinpointing a camera, measuring features and locating an object in 3D space. With these tools, MIL can make the necessary adjustments when the work plane is at a known place that is different from the calibration plane. MIL can also position an object of known geometry and dimension or a known feature using a monocular or stereoscopic imaging setup respectively. These techniques enable vision-based robot guidance.



MIL 3D Calibration

Image processing primitives

A professional imaging toolkit must include a complete set of operators for enhancing and transforming images, and for retrieving statistics in preparation for ensuing analysis. MIL includes an extensive list of fast operators for arithmetic, Bayer interpolation, color space conversion, de-interlacing, spatial and temporal filtering, geometric transformations, histogram, logic, LUT mapping, morphology, projection, segmentation, and thresholding. MIL also provides a tool that quickly extracts a structured light beam or laser line from an image to generate the depth map of an object.

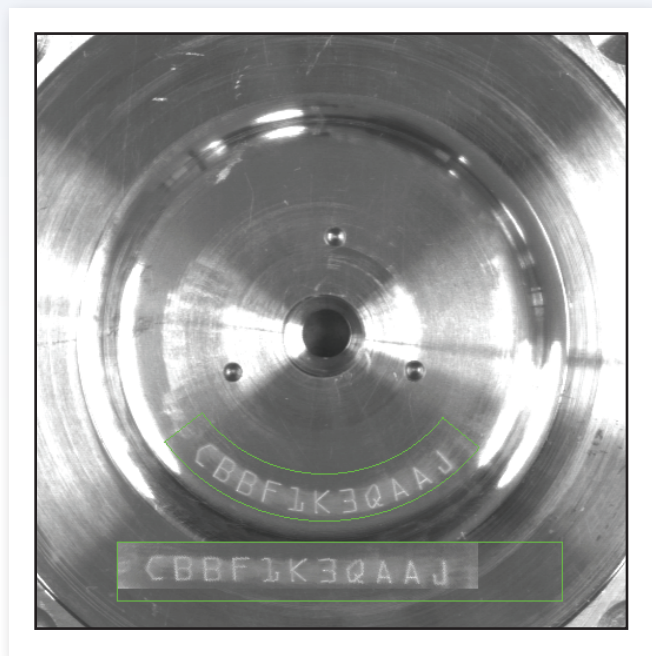
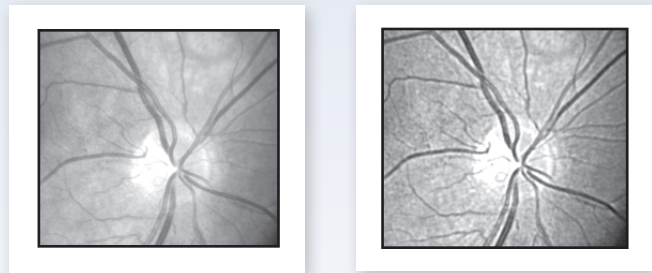

MIL Image Processing

Image analysis / measurement tools (cont.)

Compression/decompression

MIL provides image compression/decompression for optimizing storage and transmission requirements. It supports the JPEG and JPEG2000 standards in both lossy and lossless modes. MIL saves and loads compressed images stored individually using the JPG and JP2 file formats respectively or as a sequence using the AVI (Audio Video Interleave) file format. The compression parameters can be adjusted to achieve different compression factors versus image quality.

Fully optimized for speed

MIL image processing and analysis operations are optimized by Matrox to take full advantage of Streaming SIMD Extensions (SSE) instructions, as well as multi-core CPU and multi-CPU system architectures¹, to perform at top speed. MIL automatically dispatches operations across the number of processor cores needed to achieve maximum performance. Alternatively, it gives programmers control over the number of processor cores assigned to perform a given operation. MIL also totally exploits the parallel computing power in today's graphics processor unit (GPU) to offload from the host CPU and accelerate arithmetic, Bayer interpolation, color space conversion, spatial and temporal filtering, geometric transformation, LUT mapping, morphology, and thresholding operations². In addition, MIL is able to offload from the host CPU and even accelerate certain image processing operations when used with Matrox processing hardware with ASIC or FPGA technology.

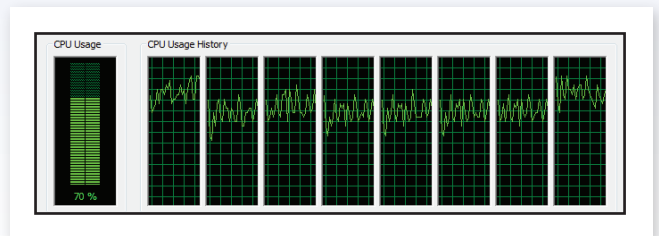
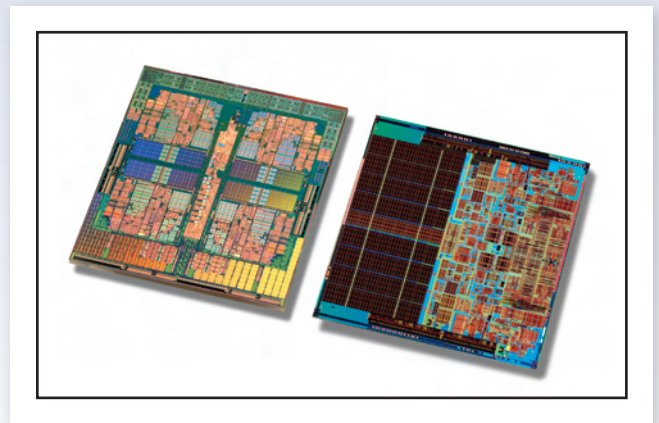

MIL takes full advantage of AMD (left) and Intel® (right) multi-core CPU and multi-CPU architectures.

Distributed MIL

Coordinate and scale performance outside the box

MIL has the ability to remotely control image capture, processing, analysis, display, and archiving over Ethernet. This Distributed MIL functionality gives the means to scale an application beyond a single computer and make the most of modern-day, high-performance computing (HPC) clusters for industrial imaging applications. The technology can also be

used to control and monitor several PCs and smart cameras deployed on a factory floor. Adding negligible overhead, Distributed MIL provides a seamless method to dispatch commands, transfer data, send and receive event notifications, and perform function callback across systems.

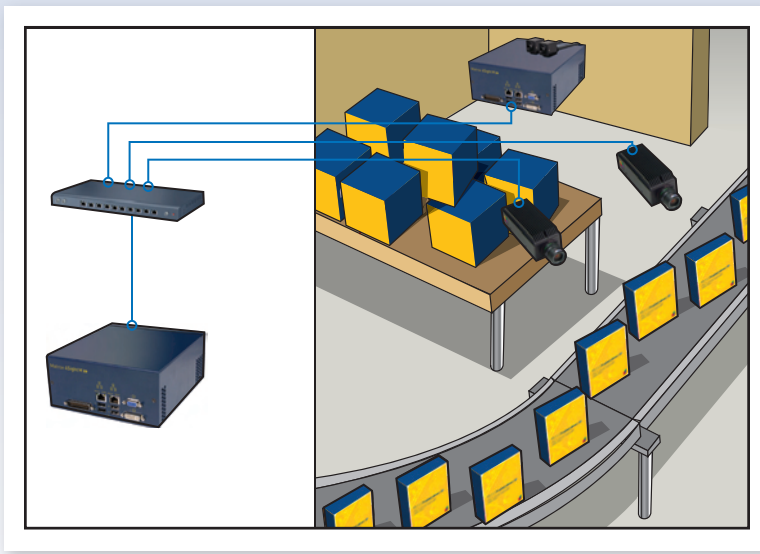

Distributed MIL can be used to control and monitor several PCs and smart cameras over a factory network.

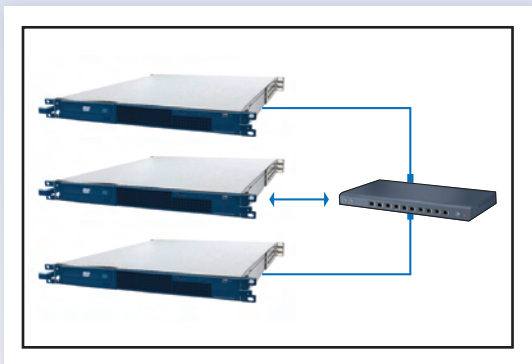

Distributed MIL can be used to make the most of HPC clusters.

Distributed MIL architecture

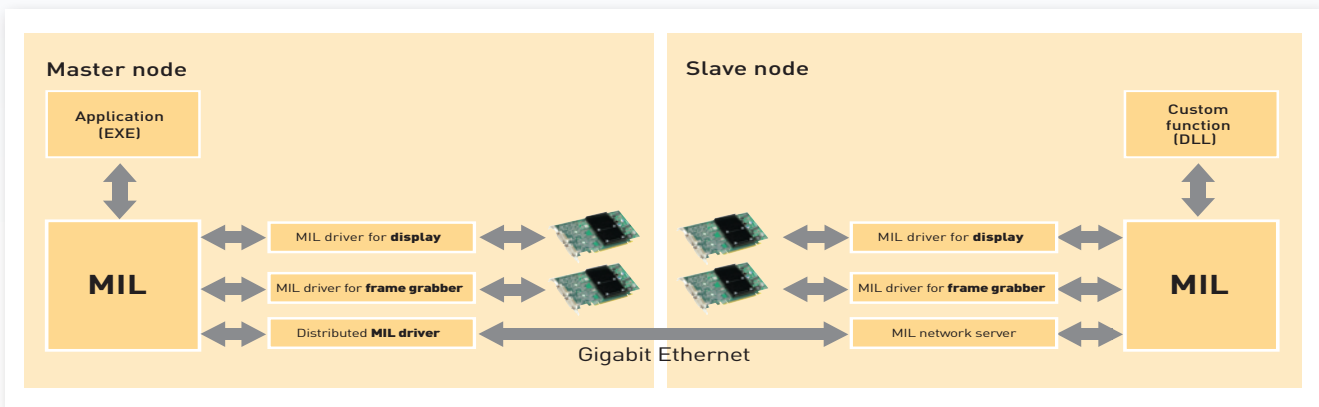

Prototype

Interactive tools

MIL comes with a set of interactive tools to help assess application feasibility and create a prototype. These interactive tools also further enhance the productivity of application developers.

Matrox Inspector

Bundled with MIL is Matrox Inspector, an integrated imaging environment for 32-bit Windows®. Matrox Inspector provides an easy-to-use interface with point-and-click access to MIL image capture, processing, analysis, and archiving operations.

In addition to displaying images, Matrox Inspector presents processing and analysis results as tables and/or graphs, including trend and distribution, which are useful for tuning operation settings. Results can be shared with other Windows®

applications, such as Microsoft® Excel®, for further analysis and reporting. The application also gives users with the ability to benchmark operations for accuracy and repeatability. In addition to making annotations, users can draw into images to perform measurements as well as touch-up and manually segment images. Matrox Inspector works with individual images or timed sequences of images stored in MIL-supported formats as well as DICOM.

Matrox Inspector also incorporates a rich scripting environment. MIL developers can record a sequence of manual operations in a script and easily apply it to a series of images. Scripts can be created in Microsoft® Visual Basic® for Applications (VBA) or 'C'-like programming languages. Users can troubleshoot scripts using an integrated debugger.

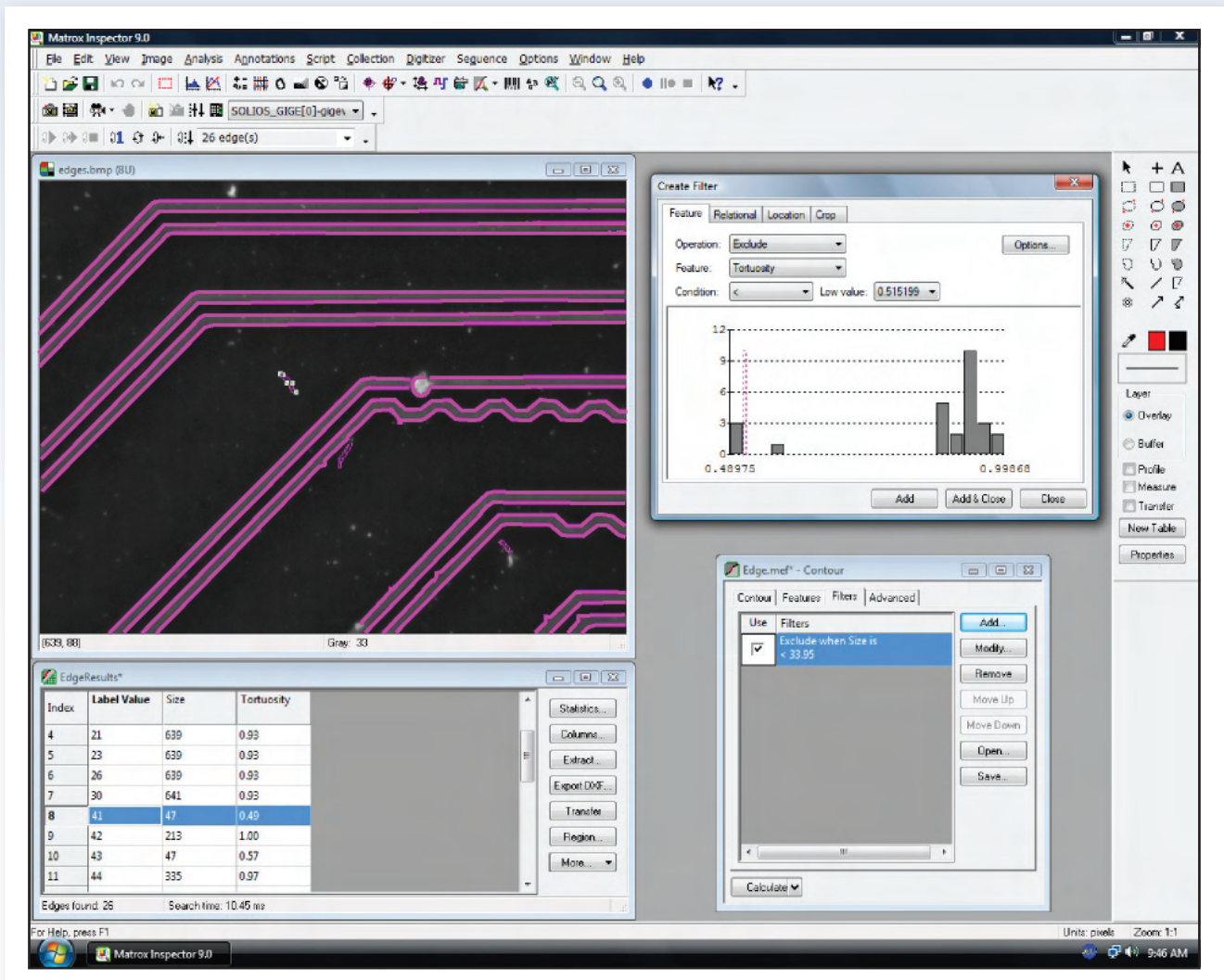

Matrox Inspector integrated imaging environment.

Prototype (cont.)

Additional processing and analysis utilities

MIL includes a collection of interactive Windows®-based utilities for each key image processing and analysis tool. Intended for configuration and experimentation, each tool supports live

image capture and processing as well as file I/O for individual or sequences of images. Tooltips over dialog controls provide a convenient cross-reference to actual MIL function calls.

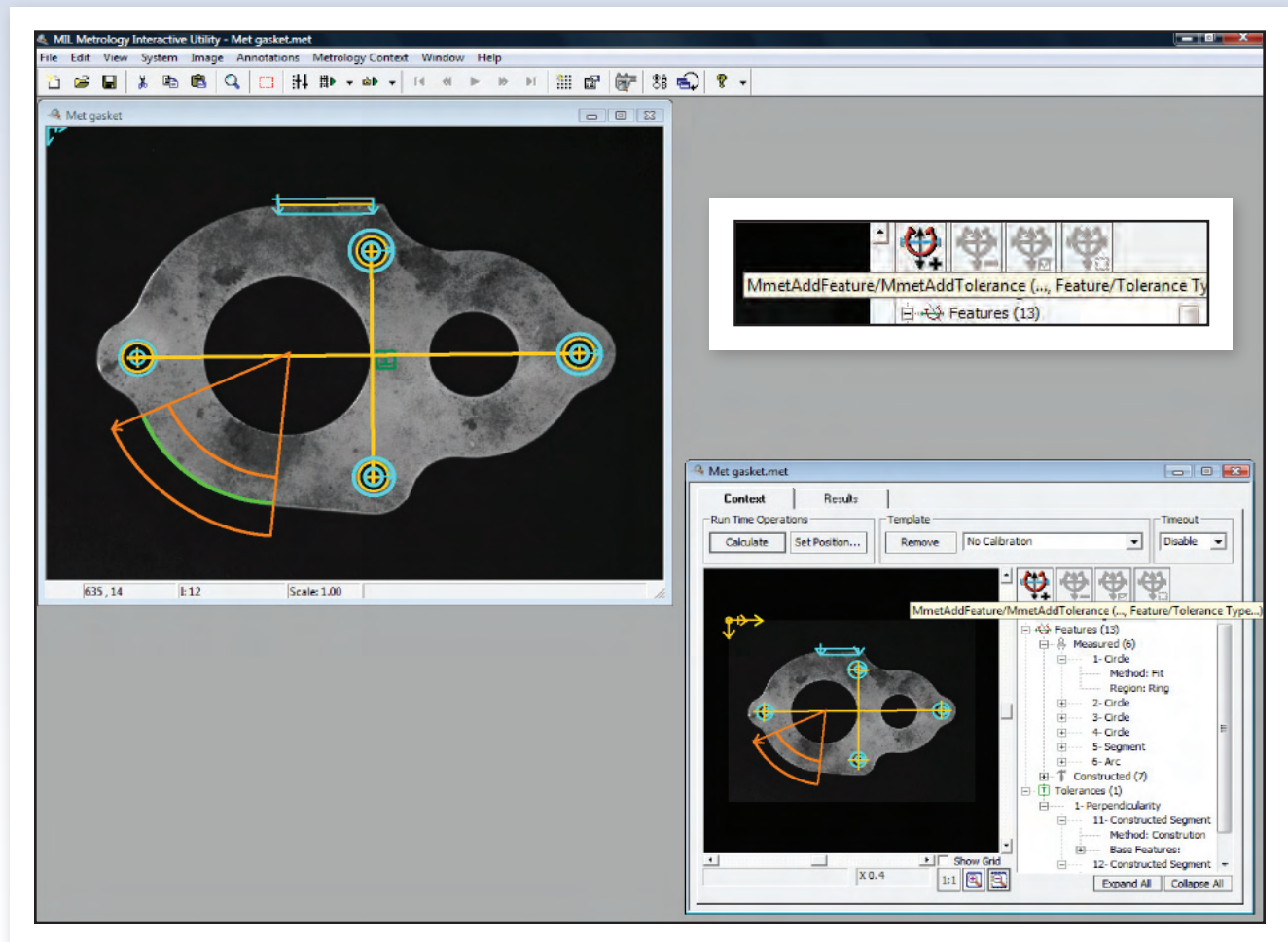

MIL includes interactive utilities for configuration and experimentation.

Prototype (cont.)

Matrox Intellicam

MIL features the Matrox Intellicam image capture and frame grabber configuration utility. This Windows®-based program lets users interactively configure Matrox image capture hardware

for a variety of image sources or simply try one of the numerous ready-made interfaces available from Matrox Imaging.

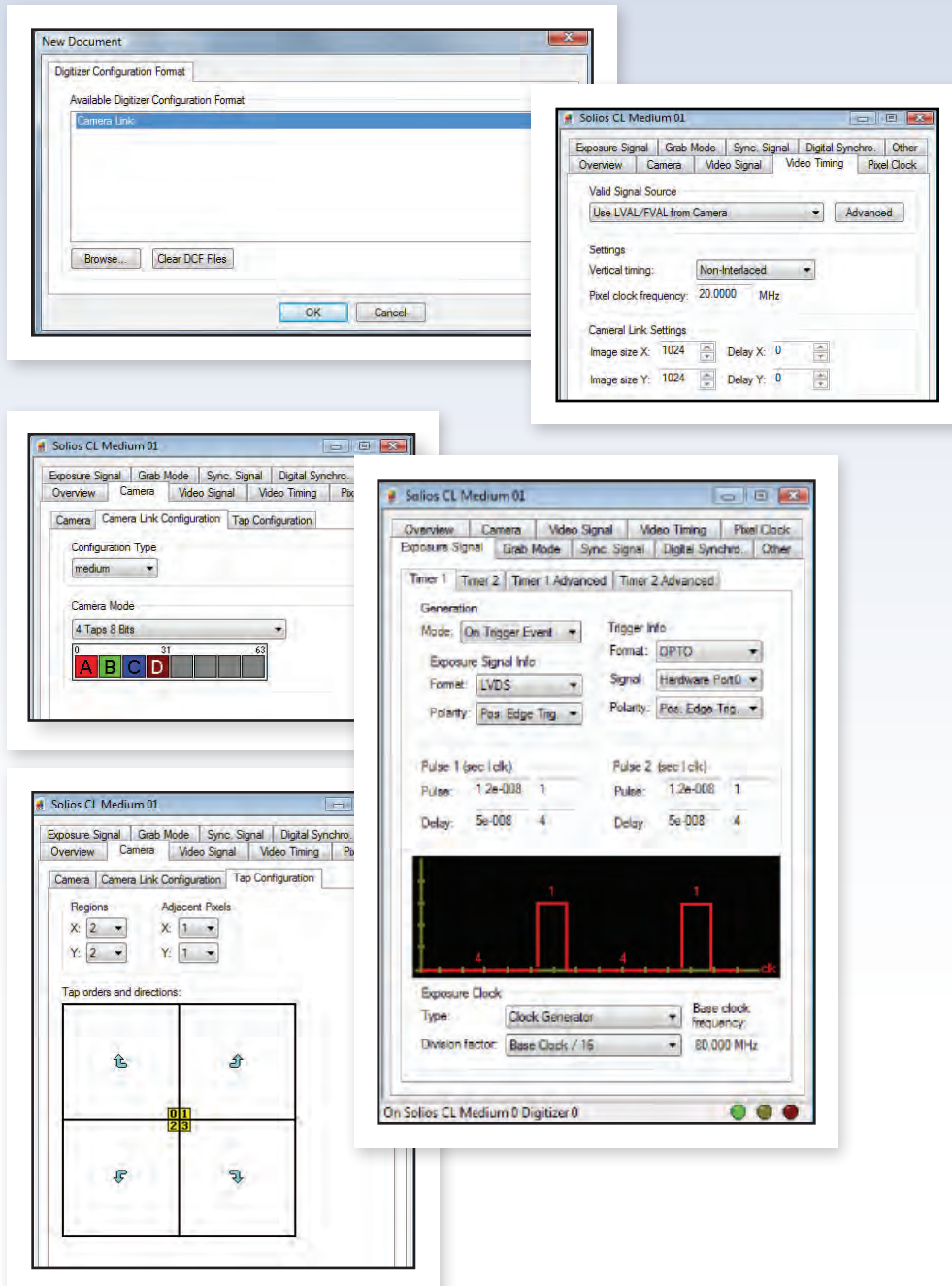

Matrox Intellicam image capture and frame grabber configuration utility.

Develop

Complete application development environment

In addition to image processing, analysis and archiving tools, MIL includes image capture, annotation and display functions, which form a cohesive API. The API and accompanying utilities are recognized, by the large installed base of users, as helping to facilitate and accelerate application development.

Portable API

The MIL C API is not only intuitive and straightforward to use but it is also portable. It allows applications to be easily moved from one supported video interface or operating system to another, which provides platform flexibility and protects the original development investment.

Simplified platform management

With MIL, a developer does not require an in-depth knowledge of the underlying platform. MIL is designed to deal with the specifics of each platform and provide simplified management (e.g., hardware detection, initialization, and buffer copy). MIL gives developers direct access to certain platform resources such as the physical address of a buffer. MIL also includes debugging services (i.e., function parameter checking, tracing and error reporting), as well as a configuration and diagnostic tools.

Designed for multi-tasking

MIL supports multi-processing and multi-tasking programming models: multiple MIL applications not sharing MIL data or a single MIL application with multiple threads sharing MIL data. It provides mechanisms to access shared MIL data and ensure that multiple threads using the same MIL resources do not interfere with each other. MIL also offers platform-independent thread management for enhancing application portability.

Supported data formats

MIL can manipulate data, such as monochrome images, stored in 1, 8, 16, and 32-bit integer, as well as 32-bit floating point formats. MIL can also handle color images stored in packed or planar RGB/YUV formats. Included are commands for efficiently converting between data types.

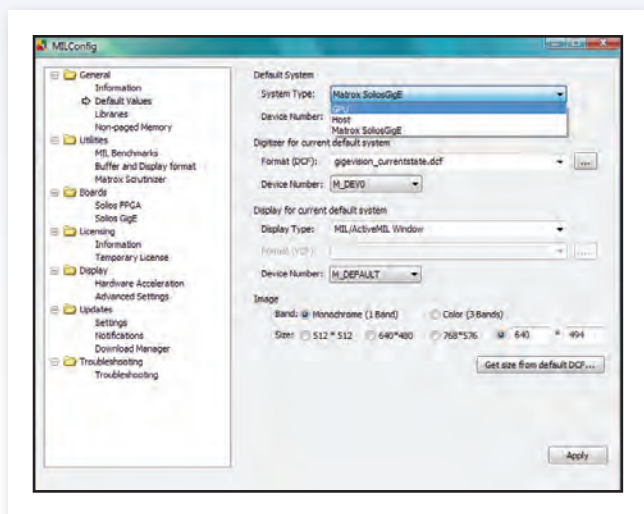

MIL configuration and diagnostic tool.

Develop (cont.)

Flexible and dependable image capture

There have never been so many ways of transmitting video: analog, Camera Link®, GigE Vision™, IEEE 1394 IIDC, LVDS, RS-422 and USB. MIL supports all these interfaces either directly through Matrox Imaging or third-party hardware, or by working in tandem with a third-party SDK. MIL works with images captured from virtually any type of color or monochrome source including standard, high-resolution, high-rate, frame-on-demand cameras, line scanners, slow scan, and custom designed devices.

For greater determinism and the fastest response, MIL provides multi-buffered image capture control performed in the operating system's kernel mode. Image capture is secured for frame rates measured in the thousands per second even when the host CPU is heavily loaded with tasks such as HMI management, networking, and archiving to disk. The multi-buffered mechanism supports callback functions for simultaneous capture and processing even when the processing time occasionally exceeds the capture time.

Saving and loading images

MIL supports the saving and loading of individual images or sequence of images to/from disk. Supported file formats are AVI (Audio Video Interleave), BMP (bitmap), JPG (JPEG), JP2 (JPEG2000), native (MIM) and TIF (TIFF), as well as a raw format.

Simplified image display

MIL provides transparent image display management with automatic tracking and updating of image display windows at live video rates. MIL also allows for image display in a user-specified window. As well, MIL supports live display of multiple video streams using multiple independent windows or a single mosaic window. Moreover, MIL provides non-destructive graphics overlay, suppression of tearing artifacts and filling the display area at live video rates. All of these features are performed with little or no host CPU intervention when using appropriate graphics hardware.

Support for GigE Vision™

For the GigE Vision™ interface, MIL provides drivers that take full advantage of the underlying hardware to offer true low CPU usage with images ready for processing. These drivers coexist with the operating systems networking stack, allowing GigE Vision™ to share the link with other communication protocols. The drivers follow the GenICam™ Standard Features Naming Convention, implementing support for mandatory, recommended and custom features, which enables real camera interchangeability. A feature browser and dedicated read/write functions are also provided to directly manage these features.



Feature Name	Value
<input checked="" type="checkbox"/> AcquisitionTrigger	
AcquisitionMode	Continuous
AcquisitionStart	N/A
AcquisitionStop	N/A
TriggerSelector	AcquisitionStart
TriggerMode	Off
TriggerSoftware
TriggerSource	
TriggerActivation	
ExposureMode	
ExposureTimeAbs	
ExposureTimeBaseAbs	
ExposureTimeBaseRel	

Feature Name
<input checked="" type="checkbox"/> AnalogControls
<input checked="" type="checkbox"/> ImageFormat
<input checked="" type="checkbox"/> AOI
<input checked="" type="checkbox"/> AcquisitionTrigger
<input checked="" type="checkbox"/> DigitalIO
<input checked="" type="checkbox"/> TimerControls
<input checked="" type="checkbox"/> LUTControls
<input checked="" type="checkbox"/> DeviceInformation
<input checked="" type="checkbox"/> ChunkDataStreams
<input checked="" type="checkbox"/> ChunkData
<input checked="" type="checkbox"/> EventsGeneration
<input checked="" type="checkbox"/> UserSets
<input checked="" type="checkbox"/> TransportLayer

MIL provides direct access to GenICam™ Standard Features.

Develop (cont.)

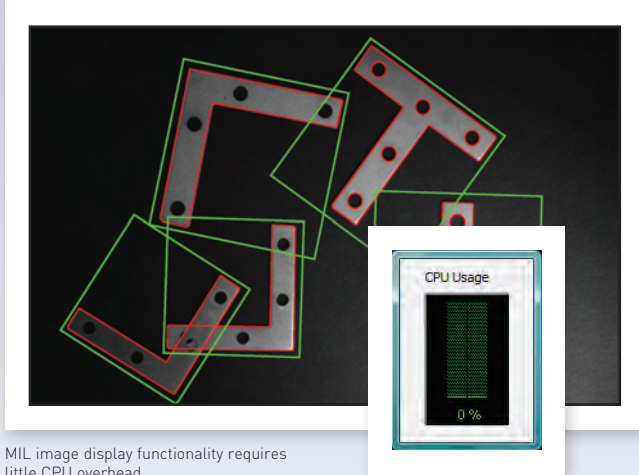

MIL image display functionality requires little CPU overhead.

Simplified image display (cont.)

MIL also supports multi-screen display configurations that are in an extended desktop mode (i.e., desktop across multiple monitors), auxiliary mode (i.e., monitor not showing desktop but dedicated to MIL display), or a combination. Multi-screen display configurations are achieved using Matrox and/or third-party graphics boards.



MIL can manage image display across multiple monitors.

Image annotation

MIL includes functions for creating image annotations consisting of graphics and text. Developers can apply custom annotations or display the results of image processing and analysis operations superimposed on an image.

Documentation, examples, and video tutorials

MIL's online help provides developers with comprehensive and easy-to-find documentation. The online help can even be tailored to match the environment in use. An extensive set of example programs and video tutorials allow developers to quickly get up to speed with MIL.

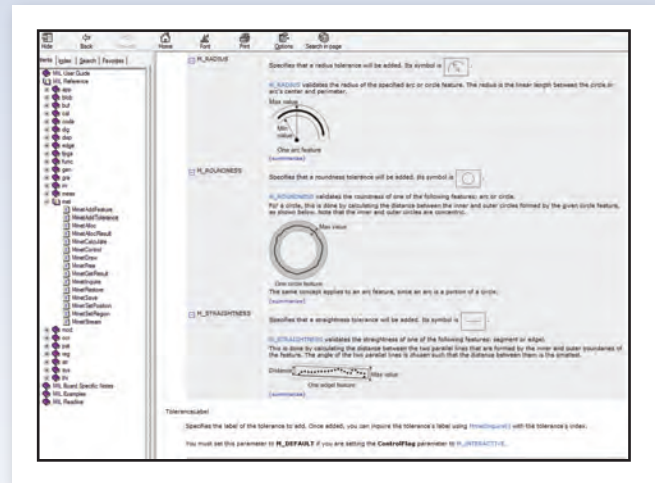

MIL includes comprehensive and easy-to-find documentation.

Application deployment

MIL offers a flexible licensing model for application deployment. Only the components required to run the application need to be licensed. License fulfillment is achieved using a hardware token or an activation code. The installation of MIL can even be hidden from the end user.

ActiveMIL for .NET development

For developing Windows® applications within the .NET Framework, MIL includes ActiveMIL, a collection of ActiveX controls (OCX) for performing image capture, processing, analysis, display, annotation, and archiving. ActiveMIL uses the Component Object Model interoperability layer (COM Interop) to enable development using managed code within Visual Basic® and Visual C#®. ActiveMIL and the .NET Framework work together to let developers quickly and create a rich and clear graphical user interface.

Develop (cont.)

MIL-Lite

MIL-Lite is a subset of MIL that includes ActiveMIL-Lite, itself a subset of ActiveMIL. MIL-Lite features programming functions for performing image capture, annotation, display, and archiving. It also includes fast operators for arithmetic, Bayer interpolation, color space conversion, de-interlacing, temporal filtering, basic

geometric transformations, histogram, logic, LUT mapping, and thresholding. MIL-Lite is licensed for both application development and deployment in the presence of Matrox Imaging hardware or a supplemental license.

Software architecture

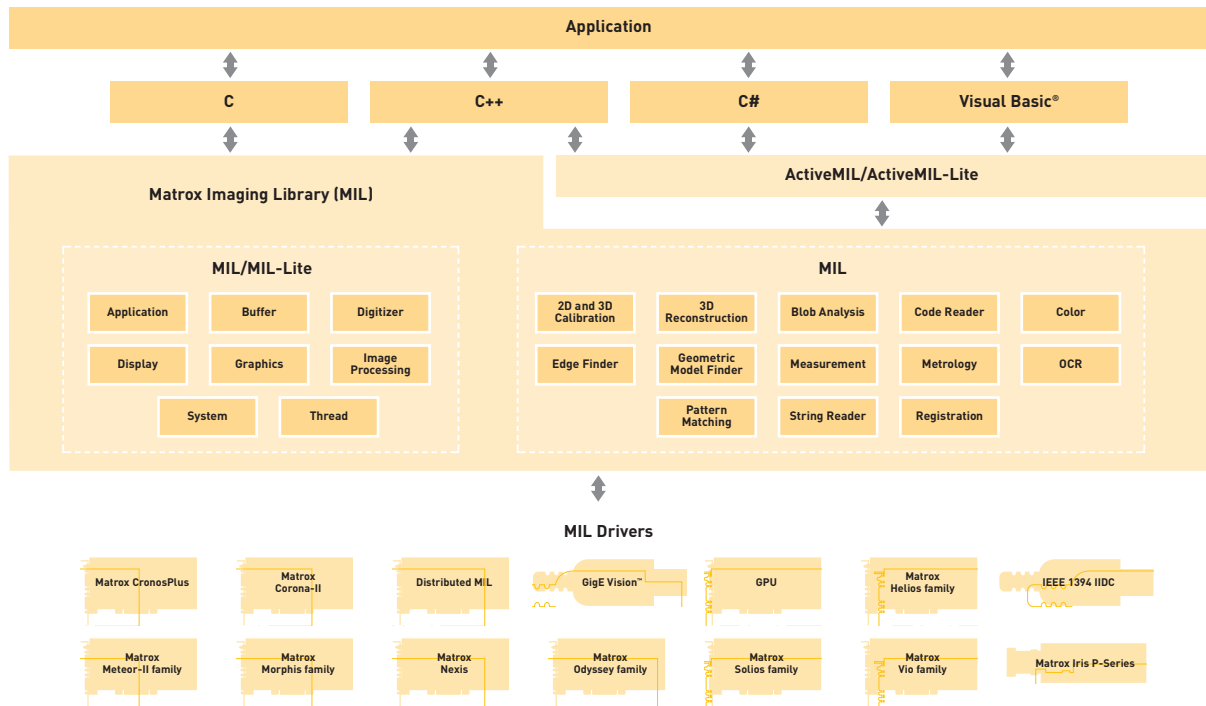

MIL provided a comprehensive set of application programming interfaces, imaging tools and hardware support

Training & Support

MIL training

Matrox Imaging regularly offers MIL training courses covering the basic software environment as well as the processing and analysis tools. The trainings are instructor-led and held at Matrox headquarters and select locations worldwide. These trainings consist of interactive lectures with hands-on programming exercises. Custom trainings, tailored to meet specific needs, are also available to be conducted at a customer's site. By participating in MIL trainings, users get to further increase productivity, reduce development costs and bring applications to market sooner. Refer to the support section at www.matrox.com/imaging for more information.



Matrox Imaging regularly holds user trainings.

MIL maintenance program

MIL provides registered users automatic enrollment in the maintenance program for one year. This maintenance program entitles registered users to free software updates and technical support from Matrox Imaging. Registered users have full access to the Matrox Imaging Developers' Forum, an online, moderated community for discussions on all Matrox Imaging products. Just before the expiration of the maintenance program, registered users will have the opportunity to extend the program for another year. For more information, refer to the Matrox Imaging Software Maintenance Programs brochure.



MIL is backed by an experienced and skilled support group.

Matrox Vision Squad

An experienced and skilled technical support group helps users with installation, interoperability and programming matters. Matrox Imaging also offers the assistance of the Vision Squad. The Vision Squad's knowledgeable staff, working closely with MIL tool developers, helps MIL users quickly assess application feasibility and establish the best strategy for using MIL processing and analysis tools to produce a solution. Services range from providing advice to delivering a proof-of-concept imaging application and even its underlying framework.



Environments

Supported environments

IDE \ OS	32-bit Windows® XP ^{5,6}	32-bit Windows® Vista ^{7,8}	64-bit Windows® XP ^{5,6} /Vista ^{7,8}	Windows® CE 6.0 ³	32 / 64-bit Linux ⁹
Visual® C++ .NET 2003 ¹⁰	MIL / ActiveMIL (unmanaged)	-	-	-	-
Visual® C++ .NET 2005 ¹¹ and 2008	MIL / ActiveMIL (unmanaged)	MIL / ActiveMIL (unmanaged)	MIL (unmanaged)	MIL (unmanaged)	-
Visual® C# .NET 2003 ¹⁰	ActiveMIL (managed)	-	-	-	-
Visual® C# .NET 2005 ¹¹ and 2008	ActiveMIL (managed)	ActiveMIL (managed)	-	-	-
Visual® Basic® .NET 2003 ¹⁰	ActiveMIL (managed)	-	-	-	-
Visual® Basic® .NET 2005 ¹¹ and 2008	ActiveMIL (managed)	ActiveMIL (managed)	-	-	-
GNU Compiler Collection ¹²	-	-	-	-	MIL

Order

Matrox Imaging Library (MIL) 9 Development Toolkits

Part number	Description
MIL 9 WIN32 P U EA	MIL 9 development toolkit for 32-bit Windows® XP / Vista®. Includes DVDs with MIL, ONL, ActiveMIL, Intellicam, Inspector, Matrox display drivers and on-line documentation. Also includes a perpetual license USB hardware key.
MIL 9 WIN32 ODY EA	MIL 9 development toolkit for Matrox Odyssey running under 32-bit Windows® XP/Vista. Includes DVDs with MIL, ONL, ActiveMIL, Intellicam, Inspector, Matrox display drivers and on-line documentation. For an unlimited number of users and royalty-free redistribution (runtime) when using a Matrox Odyssey only.
MIL 9 WIN64 EA	MIL 9 development toolkit for 64-bit Windows® XP / Vista®. Includes DVD with MIL, ONL, Intellicam, Matrox display drivers and on-line documentation. Also requires MIL9WIN32PUEA or MIL9WIN32PODYEA.
MIL 9 LNX32 EA	MIL 9 development toolkit for 32-bit Linux. Includes DVD with MIL, ONL and on-line documentation. Also requires MIL9WIN32PUEA or MIL9WIN32PODYEA.
MIL 9 LNX64 EA	MIL 9 development toolkit for 64-bit Linux. Includes DVD with MIL, ONL and on-line documentation. Also requires MIL9WIN32PUEA.

Note: 50% educational discount for MIL 9 WIN 32... with proof of institutional affiliation.
* Must be ordered at the same time and for the same end customer (customer's P.O. required as proof).

MIL-Lite 9 Development Toolkits

Part number	Description
MIL LITE 9 WIN32 EA	MIL-Lite 9 development toolkit for 32-bit Windows® XP/Vista®. Includes DVD with MIL-Lite, ActiveMIL-Lite, Intellicam, Matrox display drivers and on-line documentation.
MIL LITE 9 WIN64 EA	MIL-Lite 9 development toolkit for 64-bit Windows® XP/Vista®. Includes DVD with MIL-Lite, Intellicam, Matrox display drivers and on-line documentation. Also requires MIL LITE 9 WIN32 EA.
MIL LITE 9 LNX32 EA	MIL-Lite 9 development toolkit for 32-bit Linux. Includes DVD with MIL-Lite and on-line documentation. Also requires MIL LITE 9 WIN32 EA.
MIL LITE 9 LNX64 EA	MIL-Lite 9 development toolkit for 64-bit Linux. Includes DVD with MIL-Lite and on-line documentation. Also requires MIL LITE 9 WIN32 EA.

Note: A MIL-Lite 9 supplemental license key is required to use JPEG/JPEG2000 compression/decompression, GigE Vision™ / IEEE 1394 IIDC interface on third-party hardware, Distributed MIL or GPU processing (see MIL-Lite Supplemental Licenses section).

Note: 50% educational discount for MIL LITE 9 WIN32... , MIL LITE 9 WIN64, MIL LITE 9 LNX32 and MIL LITE 9 LNX64 with proof of institutional affiliation.

MIL/MIL-Lite Maintenance Program

Part number	Description
Included in the original purchase price of the MIL/MIL-Lite 9 development toolkit, it entitles registered users to one year of technical support and access to updates.	
MIL MAINTENANCE	One year extension to MIL maintenance program per developer.
LTE MAINTENANCE	One year extension to MIL-Lite maintenance program.

MIL/MIL-Lite Training

Part number	Description
MIL LITE TRAIN	"Introduction to the MIL/MIL-Lite Environment" training. 3 or 4-day instructor-led training includes a general overview of MIL/MIL-Lite, explains how to set up a development environment, and covers the basics of managing image buffers, image capture and display. Visit www.matrox.com/imaging/training for more information.
MIL PROC TRAIN	"Matrox Imaging Library (MIL) Processing" training. 3-day instructor-led intensive training explains how to select the best image processing tools for an application and demonstrates how to use them to their full potential. Students will have an opportunity to discuss the specifics of their project with MIL developers. Visit www.matrox.com/imaging/training for more information.

Order

MIL 9 Run-Time Licenses / MIL-Lite 9 Supplemental Licenses

Part number	Description
Software License Keys	
M9 RT x x x x x x 000	MIL 9 run-time software license key. The user must supply lock code obtained from MIL License Manager application/page. This unique lock code identifies the target computer system and MIL/ActiveMIL package(s) to license. Note: Place 0 in appropriate field (i.e., x) if package is not required.
M9 RT A x x x x x 000	MIL image analysis package. Includes Image Processing, Blob Analysis, Measurement and Calibration modules.
M9 RT M x x x x x 000	MIL machine vision package. Includes Image Processing, Blob Analysis, Pattern Matching (NGCbased), Measurement and Calibration modules.
M9RT x I x x x x 000	MIL identification package. Includes OCR and Code Reader modules.
M9RT x C x x x x 000	MIL String Reader package.
M9RT x 2 x x x x 000	Both M9RTxlxxxx000 and M9RTx-Cxxxx000.
M9 RT x x J x x x 000	MIL/MIL-Lite image compression package. Includes JPEG and JPEG2000 codecs.
M9 RT x x T x x x 000	MIL/MIL-Lite GPU Processing package. Requires appropriate additional package(s) if used with MIL (i.e., not required for MIL-Lite).
M9 RT x x B x x x 000	Both M9RTxxJxxxx000 and M9RTxx-Txxxx000.
M9 RT x x G x x x 000	MIL Geometric Model Finder package.
M9 RT x x E x x x 000	MIL Edge Finder package.
M9 RT x x 2 x x x 000	Both M9RTxxGxxx000 and M9RTxx-Exxx000.
M9 RT x x x S x x 000	MIL/MIL-Lite interface package. (GigE Vision™ and IEEE 1394 IIDC). Required if using a third-party NIC or IEEE 1394 adaptor.
M9 RT x x x D x x 000	Distributed MIL/MIL-Lite package for master or slave node.
M9 RT x x x B x x 000	Both M9RTxxxxSxx000 and M9RTxxxxDxx000.
M9 RT x x x x R x 000	MIL Registration package.
M9 RT x x x x 3 x 000 Ask for availability.	MIL 3D calibration and reconstruction package.
M9 RT x x x x 2 x 000	Both M9RTxxxxRx000 and M9RTxxxx3x000.
M9 RT x x x x x Y 000	MIL Metrology package.
M9 RT x x x x x Q 000 Ask for availability.	MIL Color Analysis package.
M9 RT x x x x x B 000	Both M9RTxxxxxY000 and M9RTxxxxxQ000.

Hardware ID Keys

MIL 9 RT ID + U	MIL/MIL-Lite run-time USB hardware fingerprint and license storage. Replaces Matrox Imaging hardware as fingerprint used to generate unique system code. M9RTxxxxxx000 still required.
-----------------	--

Hardware Licence Keys

M9RT x x x x x x 000 U	Pre-programmed MIL/MIL-Lite run-time USB hardware license key that enables appropriate package(s) (see Software License Keys for available selections). Alternative to M9 RT x x x x x x 000.
------------------------	---

Endnotes:

1. Available as of MIL 9.0 Processing Pack 1.
2. Only under Windows®.
3. With Matrox Iris E/S-Series only.
4. Protected by U.S. Patents 7,027,651; 7,319,791; 7,327,888.
5. Qualified using Windows® XP Professional with Service Pack 2.
Other editions including Windows® Server 2003 R2 may be supported.
6. Also requires .NET Framework 2.0 or later.
7. Qualified using Windows® Vista® Business edition with Service Pack 1.
Other editions including Windows Server 2008 may be supported.
8. Also requires DirectX® 9c.
9. Qualified with Red Hat Enterprise Linux 5.0 and SUSE Linux Enterprise 10.
10. With Service Pack 1.
11. With Service Pack 1 and Service Pack 1 Update.
12. With version supported by qualified distributions.

Corporate headquarters:

Matrox Electronic Systems Ltd.
1055 St. Regis Blvd.
Dorval, Quebec H9P 2T4
Canada
Tel: +1 (514) 685-2630
Fax: +1 (514) 822-6273

**For more information, please call: 1-800-804-6243 (toll free in North America) or (514) 822-6020
or e-mail: imaging.info@matrox.com or <http://www.matrox.com/imaging>**

matrox

All trademarks by their respective owners are hereby acknowledged. Matrox Electronic Systems Ltd. reserves the right to make changes in specifications at any time and without notice. The information furnished by Matrox Electronic Systems, Ltd. is believed to be accurate and reliable. However, no responsibility license is granted under any patents or patent rights of Matrox Electronic Systems Ltd. Windows and Microsoft are trademarks of Microsoft Corporation. 6-10-2008. **\$IE-4914-B**